



GEMINI® SERIES NEW CONSTRUCTION WINDOWS

INSTALLATION GUIDELINES

General

Read all guidelines prior to installing the window. Certain areas may require additional anchoring or special installation methods and accessories in order to comply with local codes and requirements. Please consult with a local code official to determine if this is the case. Additional installation accessories are available and may be specified from Dashwood.

Window sealing and flashing applications may vary based on wall construction and regional requirements.

Safety: proper safety equipment should be worn during installation of windows such as safety glasses, gloves, safety boots or shoes and appropriate clothing. Hard hats and hearing protection is also recommended and is required on most construction sites.

Gemini Installation

Gemini Series New Construction Vinyl Windows are designed for Full-Frame Installation. A variety of interior jamb extension and exterior trim and brickmould options are available to suit most any wall construction or condition.

Preparation

Check window unit to ensure it is the correct size and specification based on the intended application and has no visible damage. Ensure you have the proper tools and materials required for window installation.

Required Tools

- Tape Measure
- Level
- Carpenter's Square
- Putty Knife
- Utility Knife
- Hammer
- Staple Gun
- Screw Driver or Gun
- Caulking Gun

Required Materials:

- Self-adhering Waterproof Flashing Tape minimum 4" wide
- House Wrap
- Low-Expansion Foam Insulation
- Sealant
- Shims
- Fasteners: 1" Galvanized Roofing Nails and 2" corrosion resistant Wood Screws

Prepare Rough Opening

- Check condition of rough opening. Opening should be square and plumb.
- Check rough opening dimensions. It is recommended that the new window be 1" smaller than the rough opening in width and height. Window should be a minimum of 1/2" undersize to allow for proper fit and function. DO NOT force a window into an opening that is too small! Alter opening if required to allow for minimum clearance of 1/4" between window and wall framing.
- Cut the water resistive house-wrap barrier and fold into the rough opening as shown in [Diagram 1](#). Sill flashing or panning may also be applied to the opening.

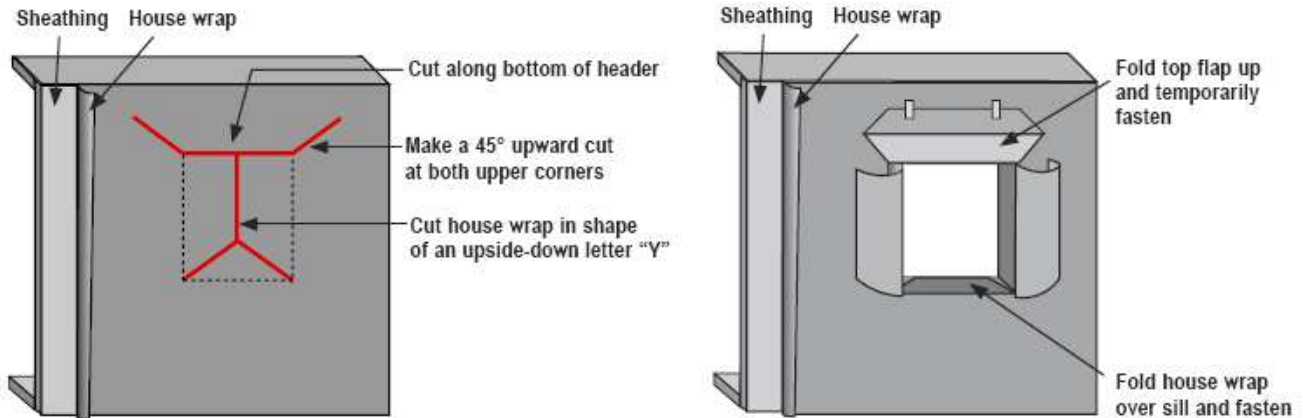

Diagram 1

Install Window

- Position unit in opening with bottom of window resting on sill with at least 1/4" clearance between window and wall framing at sides and head.
- Install roofing nails through pre-drilled holes in upper corners of the nailing flange to position the unit for final anchoring. **The nailing flange is not intended to be the only means to secure the window.**
- Based on type of window being installed insert shims at the window bottom and sides as shown on [Diagram 2a](#) so that window is square and plumb. Window sill should be level and the side jambs are parallel to each other and not tipped in as shown in [Diagram 3](#). Reveal between sash and frame should be consistent.

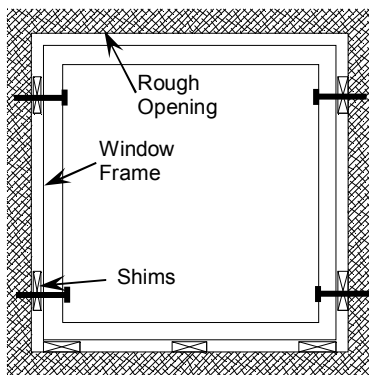

Diagram 2a

Fixed Window

3 shims on sill up to 1000mm (approx. 40") wide
 4 shims on sill up to 2400mm (approx. 96") wide
 5 shims on sill over 2400mm (approx. 96") wide

3 shims on side jamb up to 1600mm (approx. 60") tall
 4 shims on side jamb over 1600mm (approx. 60") tall

Note: Shims on side jambs are to be a minimum of 200mm (approx. 8") from the corners of the window

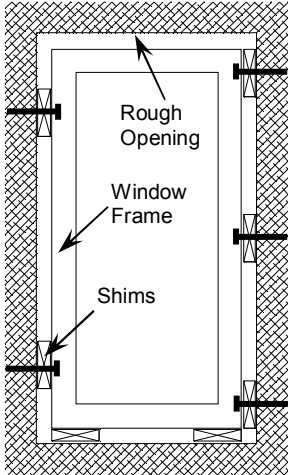

Casement Window

2 shims on sill
3 shims on hinge side

2 shims on side jamb up to 1000mm (approx. 40") tall
3 shims on side jamb up to 1600mm (approx. 60") tall
4 shims on side jamb up to 2200mm (approx. 84") tall

Note: Shims on lock side of side jamb are to be a minimum of 200mm (approx. 8") from the corners of the window

Diagram 2b

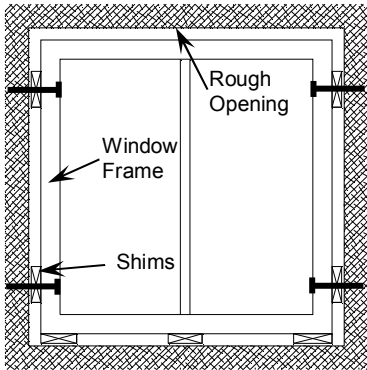

Gliding Window

3 shims on sill up to 1600mm (approx. 60") wide
5 shims on sill over 1600mm (approx. 60") wide

2 shims on side jamb up to 1000mm (approx. 40") tall
3 shims on side jamb over 1000mm (approx. 40") tall

Note: Shims on side jambs are to be a minimum of 200mm (approx. 8") from the corners of the window

Diagram 2c

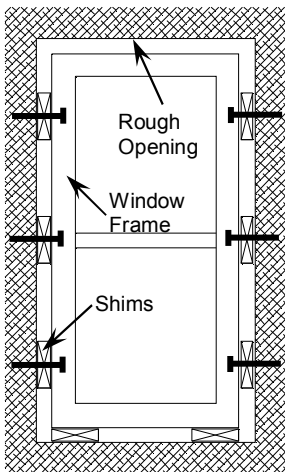

Hung Window

2 shims on sill up to 1600mm (approx. 60") wide
3 shims on sill over 1600mm (approx. 60") wide

3 shims on side jamb up to 1600mm (approx. 60") tall
5 shims on side jamb over 1600mm (approx. 60") tall

Note: Shims on side jambs are to be a minimum of 200mm (approx. 8") from the corners of the window

Diagram 2d

- Mullioned combination windows should be supported with shims at mullions in addition to the locations shown above.

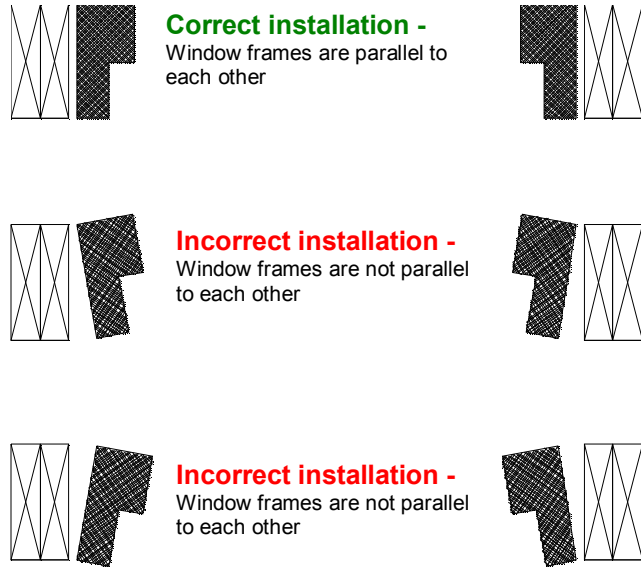

Diagram 3

- Install roofing nails through remaining pre-drilled holes in the nailing flange in every second hole to position the unit for final anchoring. **The nailing flange is not intended to be the only means to secure the window.**
- Wood screws are to be installed through frame at shimmed areas on side jambs as shown in [Diagram 2](#). Pre-drill 3/8" holes for the screws on the window as shown in [Diagram 4](#). Install screws and snugly fasten so that window remains square, plumb and level. DO NOT over tighten.

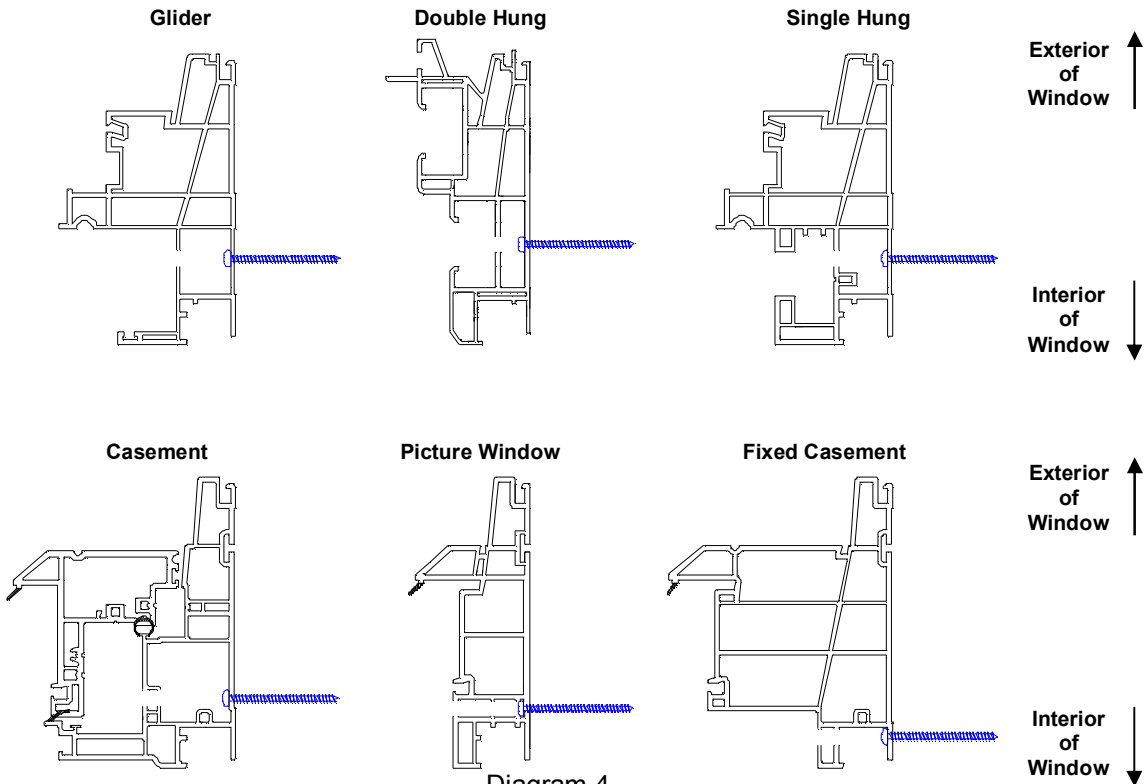

Diagram 4

-Insulate around window using batt type or low-expansion foam type insulation. Be careful not to bow or distort window frame.

Sealing and Finishing

- Check window operation and locking to ensure proper function; correct by adjust anchoring screws and shims as necessary while maintaining a plumb, level and square installation.
- On casement windows, carefully open sash and remove the red shipping blocks by inserting a screw driver in the hollow chamber and prying up.
- Optional 3/8" plugs are available from you Dashwood dealer or sales representative.
- Do not install vinyl screw hole plugs on double-hung or glider units on the lower installation holes as they will interfere with sash operation.
- Seal around the perimeter window nailing flange with self-adhering waterproof tape, overlapping the tape onto the frame 1/4" to 1/2" as shown in [Diagram 5](#). Apply starting at the sill, then sides and finally head. Fold down the top flap of the house wrap and seal with tape.
- If brick, stone or stucco exterior finish, it is recommended that a gap of at least 1/4" be left around the perimeter of the window to allow for material expansion and building settlement.
- Units with natural wood interior components should be finished promptly.

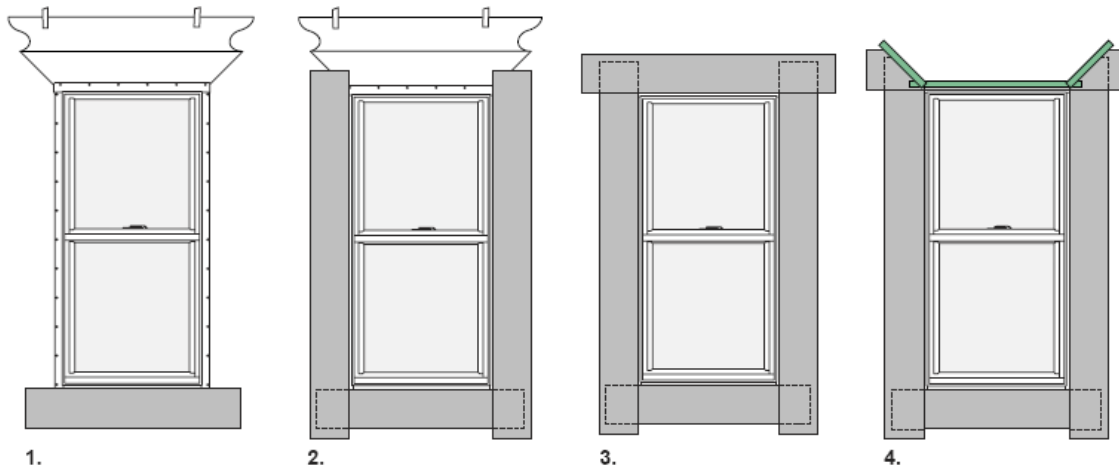

Diagram 5